

# HINO 185

## 4 x 2 CONVENTIONAL

GVW: 18,000 lbs. (MT) – 17,600 lbs. (AT)

BBC: 98"

Engine Model: J05D-TF (Turbo Intercooled)

### 2009 SPECIFICATIONS

| DIMENSIONS (On standard specification) |       |         |         |         |
|--|-------|---------|---------|---------|
| Wheelbase/Code                         | A in. | 169.0/J | 183.0/K | 201.0/M |
| Overall length                         | B in. | 266.6   | 292.6   | 310.6   |
| Overall width                          | C in. | 91.1    | 91.1    | 91.1    |
| Overall height                         | D in. | 101.4   | 101.4   | 101.4   |
| Cab to axle                            | E in. | 105.6   | 119.6   | 137.6   |
| Rear overhang                          | F in. | 63.0    | 75.0    | 75.0    |
| Frame height at:                       | G in. | 29.9    | 29.9    | 29.9    |
|  | H in. | 34.1    | 34.1    | 34.1    |
| Road clearance (at front axle)         | J in. | 7.1     | 7.1     | 7.1     |
| Tread:                                 | K in. | 72.8    | 72.8    | 72.8    |
|  | L in. | 71.9    | 71.9    | 71.9    |
| Turning radius:                        | ft.   | 46.0    | 49.4    | 53.8    |
|  | ft.   | 48.8    | 52.2    | 56.6    |

| CHASSIS WEIGHTS (On standard specification) |              |     |       |       |       |
|---|--------------|-----|-------|-------|-------|
| MT  | Total weight | lb. | 7,350 | 7,410 | 7,440 |
|   | Front axle   | lb. | 4,780 | 4,840 | 4,885 |
|   | Rear axle    | lb. | 2,570 | 2,570 | 2,555 |
| AT  | Total weight | lb. | 7,440 | 7,500 | 7,530 |
|   | Front axle   | lb. | 4,860 | 4,920 | 4,960 |
|   | Rear axle    | lb. | 2,580 | 2,580 | 2,570 |

| ENGINE                  |   |
|-------------------------|---|
| Model                   | HINO J05D-TF                                  |
| Type                    | Diesel 4-cy., 4-cyl. in-line, water-cooled    |
| Combustion system       | Direct injection type                         |
| Max. output (SAE Gross) | 175HP at 2,500 rpm                            |
| Max. torque (SAE Gross) | 376 lb.-ft. at 1,600 rpm                      |
| Bore and stroke         | 4.41 x 4.72 in.                               |
| Piston displacement     | 4.730L  |
| Fuel injection pump     | Radial plunger pump (HP-3)                    |
| Governor                | Electronically controlled                     |
| Intake system           | Turbocharged and intercooled                  |
| Air cleaner             | Paper filter type (Donaldson)                 |
| Fan clutch              | Bimetal thermostat sensor regulates fan speed |
| Glow plugs              | Standard                                      |
| Air compressor          | Single cylinder, 6.8 cfm @ 1,250 rpm          |

| POWERTRAIN AND PERFORMANCE            |                               |   |                               |
|---------------------------------------|-------------------------------|---|-------------------------------|
| 18,000 lbs. GVW and 225-70R19.5 tires |                               |   |                               |
| Powertrain                            | <input type="checkbox"/> STD. | <input type="checkbox"/> OPT.               | <input type="checkbox"/> OPT. |
| Max. speed mph                        | 78                            | 75*   | 71*                           |
| Startability (tan.θ) %                | 46.5                          | 49.5  | 52.8                          |
| Transmission Model                    | Eaton FS4205A                 | Allison 1000HS/RDS                          |                               |
|                                       | Type                          | Five-speed direct drive synchromesh 2nd-5th | Six-speed automatic           |
| Ratios                                | 1st.                          | 8.052                                       | 3.102                         |
|                                       | 2nd.                          | 4.352                                       | 1.811                         |
|                                       | 3rd.                          | 2.448                                       | 1.406                         |
|                                       | 4th.                          | 1.476                                       | 1.000                         |
|                                       | 5th.                          | 1.000                                       | 0.712                         |
|                                       | 6th.                          | –   | 0.610                         |
|                                       | Rev.                          | 8.052                                       | 4.492                         |
| Rear axle gear ratios                 | 3.580                         | 4.880                                       | 5.130                         |

Optio ratio is combined with 17,600 lbs. GVW  
 (\*) Maximum speed is limited with speed limiter

| ROADSIDE ASSISTANCE                |   |
|------------------------------------|---|
| HinoWatch (service free of charge) | 3-year unlimited roadside assistance  |
|                                    | <ul style="list-style-type: none"> <li>• Lockout</li> <li>• Out of Fuel</li> <li>• Battery Jumpstart</li> <li>• Information</li> <li>• Warranty Towing</li> </ul> |

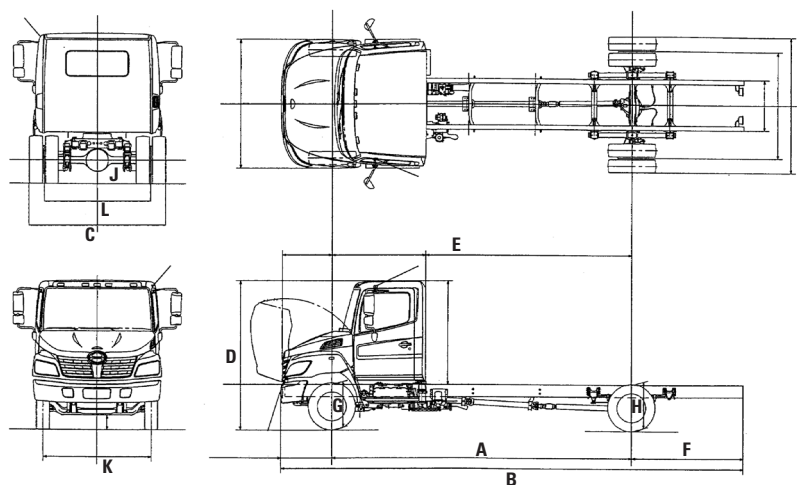

# HINO 185

**4 x 2 CONVENTIONAL**  
**GVW:** 18,000 lbs.-MT, 17,600 lbs.-AT  
**BBC:** 98"  
**Engine Model:** J05D-TF (Turbo Intercooled)

**SPEC NO.** SS-NC016  
**FORM NO.** HSS185 0708

## WEIGHT CAPACITIES

|              |      |        |
|--------------|------|--------|
| Front axle   | lbs. | 6,250  |
| Rear axle    | lbs. | 13,000 |
| Front spring | lbs. | 6,000  |
| Rear spring  | lbs. | 13,000 |

## LIQUID CAPACITIES

|                |      |   |
|----------------|------|---|
| Fuel tank      | gal. | 35  |
| Cooling system | gal. | 5.29 : Eaton FS4205A<br>5.16 : Allison 1000HS |
| Engine oil     | qt.  | 10.73   |

## AXLE/SUSPENSION

|              |   |
|--------------|---|
| Front axle   | MFS-6 series reversed Elliot, "I" beam  |
| Front spring | Taper-leaf springs shock absorbers  |
| Rear axle    | RS13-120 series Full-floating, single reduction Single-speed by hypoid gearings |
| Rear spring  | Semi-elliptic main and auxiliary helper-leaf spring                             |

## FRAME

|                                     |          |                             |
|-------------------------------------|----------|-----------------------------|
| Ladder type                         |          | Straight C Channel          |
| Width                               | in.      | 34                          |
| Yield strength                      | PSI      | 80,000                      |
| Resisting bending moment (one side) | in.-lbs. | 655,100<br>no reinforcement |

## STEERING

|                               |   |
|-------------------------------|---|
| Steering column adjustability | Tilt and telescopic with lock                                 |
| Steering system               | TRW recirculating ball, with hydraulic booster, integral type |

## CLUTCH

|                      |  |
|----------------------|--|
| Type                 | Dry single plate with damper springs Eaton-Spicer AR350 series |
| Facing material      | Cerametallic   |
| Facing outside (in.) | 13.8   |
| Control              | Hydraulic  |

## WHEELS/TIRES

|                        |                                |
|------------------------|--------------------------------|
| 6 Wheels               | 19.5 x 6.00RW 8-stud disc.     |
| Wheel style            | Steel, powder coated           |
| 6 Tires                | 225/70R19.5(F)                 |
| Tire brand and pattern | Bridgestone Fr-rib Rr-lug type |

## BRAKES

|  |   |
|--|---|
| Service brake                              | Hydraulic system with disc brake for front and rear wheels, with automatic adjustment |
| Disc diameter x pad area x thickness (in.) | Front;<br>12.756 x 17.05 x 0.61<br>Rear;<br>15.375 x 18.96 x 0.74                     |
| Control                                    | Hydraulic dual circuit with Antilock Brake System(ABS)                                |
| Parking brake                              | Mechanical, internal expanding acting on transmission output shaft                    |
| Drum diameter (in.)                        | 10 : Meritor (Auto)<br>9 : Bosch (Manual)   |
| Exhaust brake                              | Electric-pneumatic with valve in exhaust pipe   |

## CAB EQUIPMENT

|                           |  |
|---------------------------|--|
| Cab construction          | All steel welded   |
| Seating capacity          | Three  |
| Driver's seat             | Adjustable reclining, covered with vinyl with coil suspension  |
| Passenger's seat          | Bench type, covered with vinyl                                 |
| Seat belts                | 3-point type (driver and passenger), one 2-point type (center) |
| Air conditioning          | Standard   |
| Heater/Defroster          | 18,357 BTU/h   |
| Mirrors, outside rearview | Four, 1-flat and 1-convex at each side                         |
| Sun visors                | Two  |
| Over-head consoles        | Two  |
| Ventilator                | Electric forced air  |
| Windshield                | Laminated  |
| Windshield wipers         | Dual electric, 2-speed and intermittent                        |
| Cup holders               | Two at center cluster (Single)-for MT, (Dual)-for AT           |
| Cigarette lighter         | Equipped   |
| Speakers                  | Two for front  |
| Coat hook                 | One (rear panel)   |
| Door pockets              | Two  |
| Cruise control            | Standard   |

## DASH INSTRUMENTATION

|  |  |
|--|--|
| Meters and gauges ft. lb. system       |  |
| Speedometer-mph (km/h)                 |  |
| Odometer (mile)                        |  |
| Fuel gauge                             |  |
| Coolant temperature gauge              |  |
| Engine tachometer                      |  |
| Warning and pilot lamps and buzzers    |  |
| Oil pressure warning lamp and buzzer   |  |
| Brake pressure warning lamp and buzzer |  |
| Coolant level warning lamp and buzzer  |  |
| Battery charging warning lamp          |  |
| High beam indicator lamp               |  |
| Turn signal pilot lamp                 |  |
| Parking brake warning lamp             |  |
| Engine control system warning lamp     |  |
| ABS warning lamp                       |  |
| Driver Information Display             |  |
| Instant and trip fuel consumption      |  |
| DPR monitor                            |  |
| Maintenance                            |  |
| Engine/vehicle diagnostics             |  |

## ELECTRICAL EQUIPMENT

|                                    |   |
|------------------------------------|---|
| Batteries                          | Two, parallel connection, each 12V                              |
| Capacity                           | 1200 CCA  |
| Alternator                         | 12 V, 100 A, brush Delco  |
| Starter                            | 12 V, 2.5 kW Denso  |
| Car audio                          | AM/FM radio with CD   |
| Headlamps                          | Daylight running - integrated with turn signal and hazard lamps |
| Identification lamps (front)       |   |
| Stop/Tail lamps                    |   |
| Back-up lamps                      |   |
| Side-flasher lamp                  |   |
| Front side marker lamps            |   |
| Trucklite LED marker lamps (front) |   |
| Electric horn (dual)               |   |

## CHASSIS EQUIPMENT

|                 |   |
|-----------------|---|
| Radiator grille | Chrome  |
| Fuel tank       | Aluminum  |
| Fuel pre-filter | Heated pre-filter (dust) and sedimenter (water) with heater |
| Reflectors      | Two rear, two front side                                    |
| Tow hook        | One at front  |
| Air dryer       | NABCO, heat   |
| Air tank        | 49L   |

## CAB CONFIGURATION OPTIONS

|              |   |
|--------------|---|
| Extended cab | 30" cab extension, available with full-width bench seat or 26" day bunk |
|--------------|---|

## OPTIONAL EQUIPMENT

|   |
|---|
| Alternator - 12 V, 105 A, brushless   |
| Battery - Three parallel connection each 12 V (80 AH)                                   |
| Bumper, front - Black and 4 inch extension  |
| Bumper, front - White and 4 inch extension  |
| Bumper, front - Chrome and 4 inch extension   |
| Bumper, front - Chrome (available with one or two tow hooks)                            |
| Cold weather package<br>- Heated mirrors (available in chrome)<br>- Engine block heater |
| Engine block heater   |
| Mirrors, outside rearview - Heated with marker light                                    |
| Mirrors, outside rearview - Chrome, heated with marker light                            |
| Mirrors, outside rearview - Chrome  |
| Power windows and power door locks  |
| Seat - Driver's seat with air suspension  |
| Seats - Vinyl with reclining single person passenger seat                               |
| Seats - Fabric with reclining single person passenger seat                              |
| Seats - Fabric with two person bench seat   |
| Seating capacity - Two or three person  |
| Shock absorbers, rear   |
| Stabilizer, front - With shock absorber   |
| Tire pattern - Rib on rear  |
| Tow hooks - Two at front  |
| Transmission, automatic - Allison 1000 HS (rear axle ratio 4.88)                        |
| Transmission, automatic - Allison 1000 RDS with PTO drive gear (rear axle ratio 5.13)   |
| Wheels - Alcoa polished aluminum (inner rear wheels are steel)                          |
| Engine idle throttle knob - Removed   |
| Exhaust brake - Disengage   |

## NOTE:

All specifications of the products are with normal manufacturing allowances and tolerances. HINO MOTORS SALES U.S.A., INC. reserves the right to alter specifications at any time without previous notice. Some optional items of equipment may require extra time due to the need for their adaptation on the product line.